

▶ HOLE SAWS

HSS hole saws are used to saw through holes into various materials. The basic body is made of tool steel and has a HSS annular gear welded onto it. The crosswise put arrangement of the HSS saw teeth masters effortless the usage in steel and sheet irons, non-ferrous and light metals, wood, plasterboard, plastic, acrylic glass and many more.

The hole saws equipped with a HSS cobalt annular gear can also be used with stainless steels such as V2A and V4A sheets. The total height of the hole saws varies between 55mm and 43.5mm, depending on the size. GSR hole saws have a so called Vario-toothing.

VARIO TOOTHING
This type of toothing has alternate 4-6 different sized teeth per inch (tpt – teeth per inch).

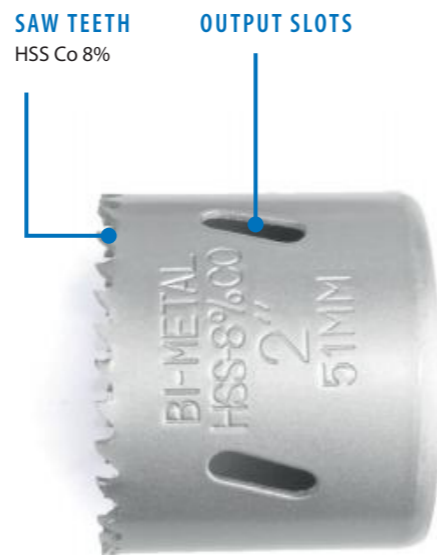

SDS SHANK
The chuck has a diameter of 10mm and enables a quick drill exchange without tools. The drill lock and torque transmission are separated.

The abbreviation SDS originated from the German "Streck, Dreh, Sitz" (stretch, twist, sit). Nowadays, the international name Special Direct System is used.

DRILLING

DRILLING

HOLE SAWS



TECHNICAL INFORMATION

Material	HSS
Raw material	M3 quality
special alloyed tool body	

Size	Inches	Art.-No.
14	9/16	04400014
16	5/8	04400016
17	11/16	04400017
19	3/4	04400019
20	25/32	04400020
21	13/16	04400021
22	7/8	04400022
24	15/16	04400024
25	1	04400025
27	1-1/16	04400027
29	1-1/8	04400029
30	1-3/16	04400030
32	1-1/4	04400032
33	1-5/16	04400033
35	1-3/8	04400035
37	1-7/16	04400037
38	1-1/2	04400038
40	1-9/16	04400040
41	1-5/8	04400041
43	11/16	04400043
44	1-3/4	04400044
46	1-13/16	04400046
48	1-7/8	04400048
51	2	04400051
52	2-1/16	04400052
54	2-1/8	04400054
57	2-1/4	04400057
59	2-5/16	04400059
60	2-3/8	04400060
64	2-1/2	04400064

Size	Inches	Art.-No.
65	2-9/16	04400065
67	2-5/8	04400067
68	2-11/16	04400068
70	2-3/4	04400070
73	2-7/8	04400073
76	3	04400076
79	3-1/8	04400079
83	3-1/4	04400083
86	3-3/8	04400086
89	3-1/2	04400089
92	3-5/8	04400092
95	3-3/4	04400095
98	3-7/8	04400098
102	4	04400102
105	4-1/8	04400105
108	4-1/4	04400108
111	4-3/8	04400111
114	4-1/2	04400114
121	4-3/4	04400121
127	5	04400127
133	5-1/4	04400133
140	5-1/2	04400140
146	5-3/4	04400146
152	6	04400152
160	6-19/64	04400160
168	6-5/8	04400168
177	6-31/32	04400177
200	7-7/8	04400200
210	8-17/64	04400210

HOLE SAWS



TECHNICAL INFORMATION

Material	HSSE
Raw material	M35 quality with 5% cobalt
special alloyed tool body	

Size	Inches	Art.-No.
14	9/16	04405014
16	5/8	04405016
17	11/16	04405017
19	3/4	04405019
20	25/32	04405020
21	13/16	04405021
22	7/8	04405022
24	15/16	04405024
25	1	04405025
27	1-1/16	04405027
29	1-1/8	04405029
30	1-3/16	04405030
32	1-1/4	04405032
33	1-5/16	04405033
35	1-3/8	04405035
37	1-7/16	04405037
38	1-1/2	04405038
40	1-9/16	04405040
41	1-5/8	04405041
43	11/16	04405043
44	1-3/4	04405044
46	1-13/16	04405046
48	1-7/8	04405048
51	2	04405051
52	2-1/16	04405052
54	2-1/8	04405054
57	2-1/4	04405057
59	2-5/16	04405059
60	2-3/8	04405060
64	2-1/2	04405064

Size	Inches	Art.-No.
65	2-9/16	04405065
67	2-5/8	04405067
68	2-11/16	04405068
70	2-3/4	04405070
73	2-7/8	04405073
76	3	04405076
79	3-1/8	04405079
83	3-1/4	04405083
86	3-3/8	04405086
89	3-1/2	04405089
92	3-5/8	04405092
95	3-3/4	04405095
98	3-7/8	04405098
102	4	04405102
105	4-1/8	04405105
108	4-1/4	04405108
111	4-3/8	04405111
114	4-1/2	04405114
121	4-3/4	04405121
127	5	04405127
133	5-1/4	04405133
140	5-1/2	04405140
146	5-3/4	04405146
152	6	04405152
160	6-19/64	04405160
168	6-5/8	04405168
177	6-31/32	04405177
200	7-7/8	04405200
210	8-17/64	04405210

HOLE SAW CHUCKS

with SDS shank and spot drill



Size	Art.-No.
14 – 30	04402030
32 – 152	04402152

GUIDE DRILLS

Material HSSG



Size	Total length	Art.-No.
6,35	70	04404070
6,35	115	04404115

HOLE SAW CHUCKS

with SDS shank and spot drill



Size	Art.-No.
14 – 30	04401030
32 – 152	04401152

HOLE SAW EXTENTION

Material Tool steel



Size	Total length	Art.-No.
9,5	300	04404170

SET



TECHNICAL INFORMATION

Material	HSS Bi-Metall
Raw material	M3 quality

Specification	HOLE SAWS	Supplies	Pieces	Art.-No.
Electrician set	22 / 29 / 35 / 44 / 51 / 64 / 68 mm	2 Chucks with hexagon shank 2 Spare guide drills	12	04403100
Plumber set	16 / 19 / 24 / 29 / 38 / 44 / 57 67 mm	2 Chucks with hexagon shank 2 Spare guide drills	13	04403110
DIY set	16 / 19 / 22 / 29 / 35 / 44 / 52 / 57 67 mm	2 Chucks with hexagon shank 2 Spare guide drills	14	04403120
Universal set	16 / 19 / 22 / 25 / 29 / 32 / 35 / 38 44 / 51 / 64 / 76 mm	2 Chucks with hexagon shank 2 Spare guide drills	17	04403130

SET



TECHNICAL INFORMATION

Material	HSS-Co8 Bi-Metall
Raw material	M42 quality

Specification	HOLE SAWS	Supplies	Pieces	Art.-No.
Electrician set	22 / 29 / 35 / 44 / 51 / 64 / 68 mm	2 Chucks with hexagon shank 2 Spare guide drills	12	04403200
Plumber set	16 / 19 / 24 / 29 / 38 / 44 / 57 67 mm	2 Chucks with hexagon shank 2 Spare guide drills	13	04403210
DIY set	16 / 19 / 22 / 29 / 35 / 44 / 52 / 57 67 mm	2 Chucks with hexagon shank 2 Spare guide drills	14	04403220
Universal set	16 / 19 / 22 / 25 / 29 / 32 / 35 / 38 44 / 51 / 64 / 76 mm	2 Chucks with hexagon shank 2 Spare guide drills	17	04403230